



US 20140132148A1

(19) **United States**

(12) **Patent Application Publication**  
**Jang et al.**

(10) **Pub. No.: US 2014/0132148 A1**

(43) **Pub. Date: May 15, 2014**

(54) **ORGANIC LIGHT EMITTING DIODE (OLED) DISPLAY**

**Publication Classification**

(71) Applicant: **SAMSUNG DISPLAY CO., LTD.**,  
Yongin-city (KR)

(51) **Int. Cl.**  
**H05B 33/04** (2006.01)

(72) Inventors: **Cheol Jang**, Yongin-city (KR);  
**Seung-Hun Kim**, Yongin-city (KR);  
**Seung-Yong Song**, Yongin-city (KR)

(52) **U.S. Cl.**  
CPC ..... **H05B 33/04** (2013.01)  
USPC ..... **313/504**

(73) Assignee: **Samsung Display Co., Ltd.**, Yongin-city (KR)

(57) **ABSTRACT**

An organic light emitting diode (OLED) display is disclosed. In one aspect, the display includes a substrate having a light emission area and a non-emission area outside the light emission area, an organic light emitting unit formed on the light emission area and a blocking unit that is disposed on the non-emission area to surround the organic light emitting unit. The OLED display further includes a coating unit formed to coat an external surface of the blocking unit and an encapsulation unit formed by alternately stacking at least one first thin film and at least one second thin film on an area surrounded by the blocking unit so as to encapsulate the organic light emitting unit.

(21) Appl. No.: **13/801,973**

(22) Filed: **Mar. 13, 2013**

(30) **Foreign Application Priority Data**

Nov. 14, 2012 (KR) ..... 10-2012-0129101

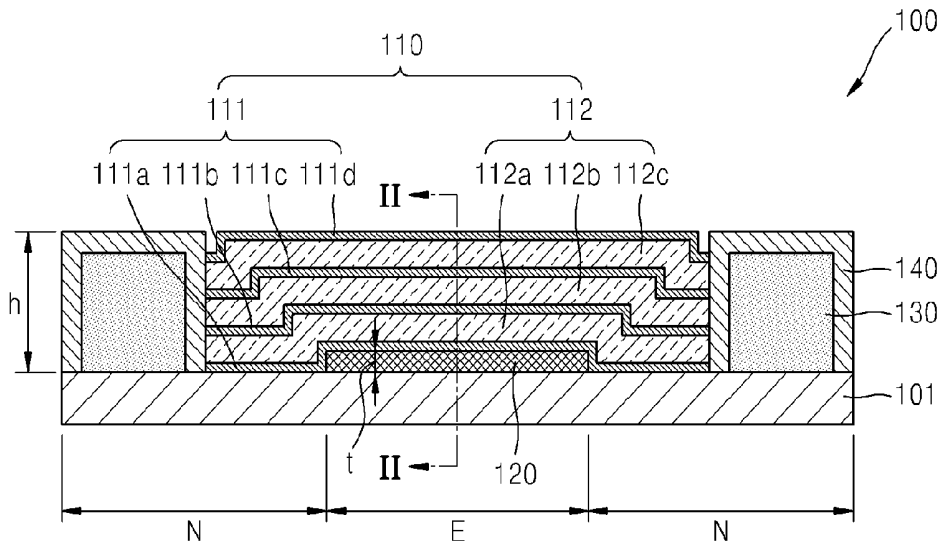

FIG. 1

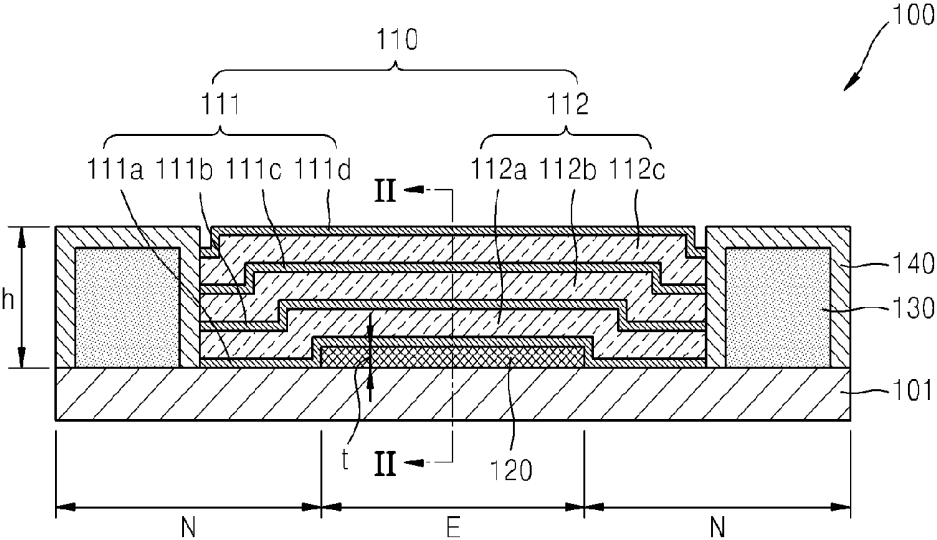

FIG. 2

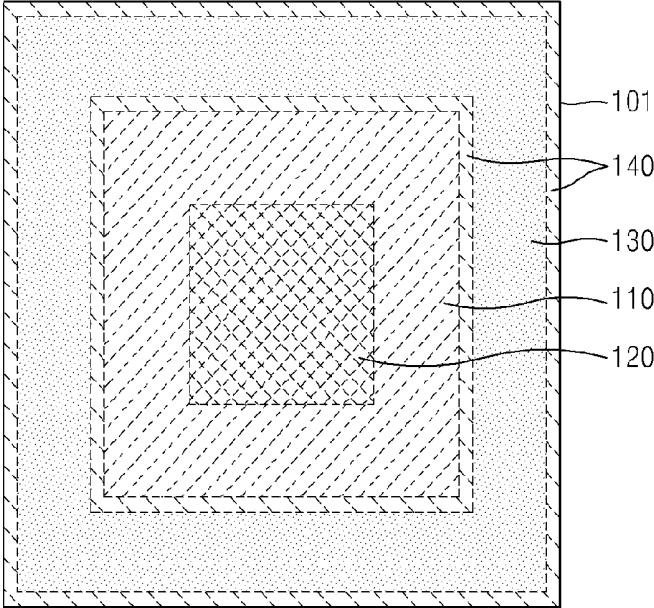

FIG. 3

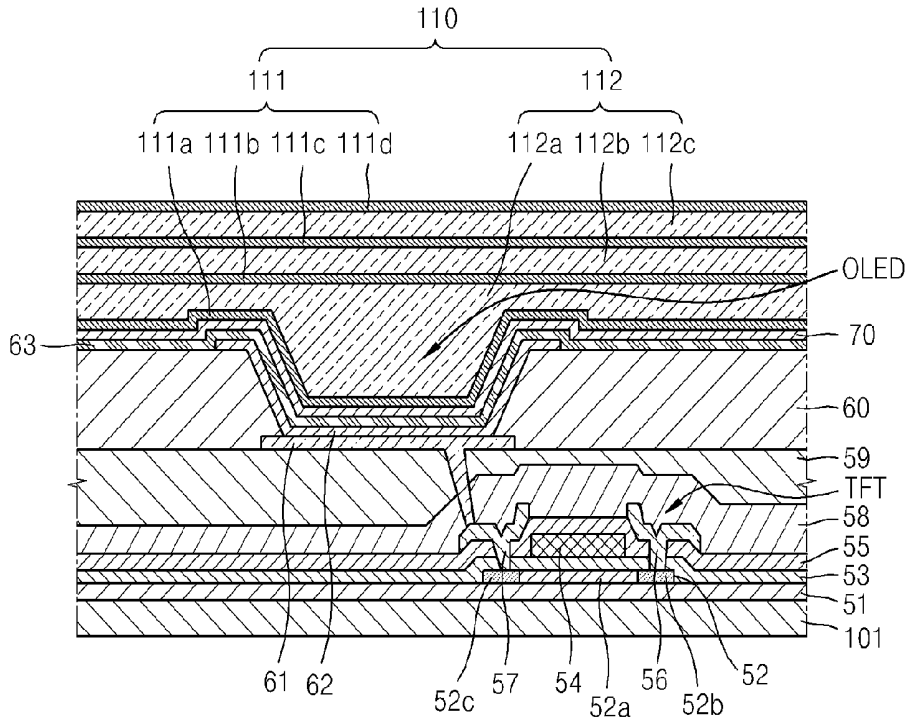

FIG. 4

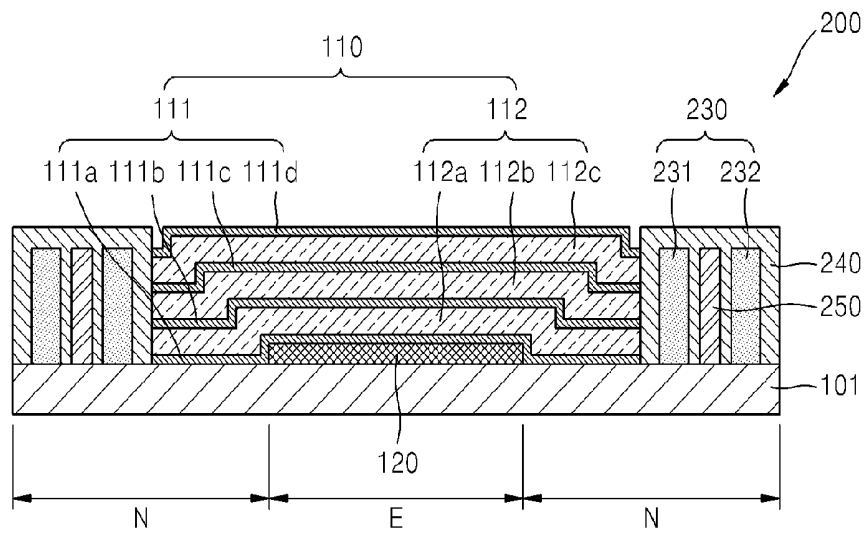

FIG. 5

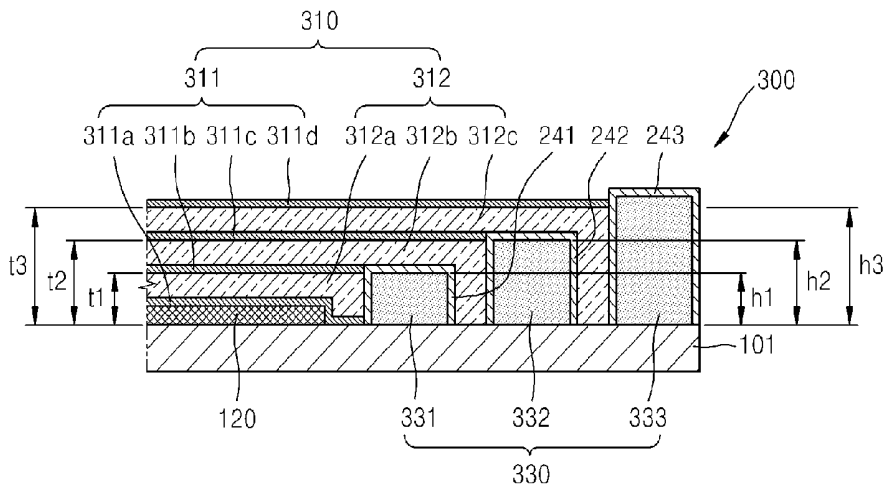
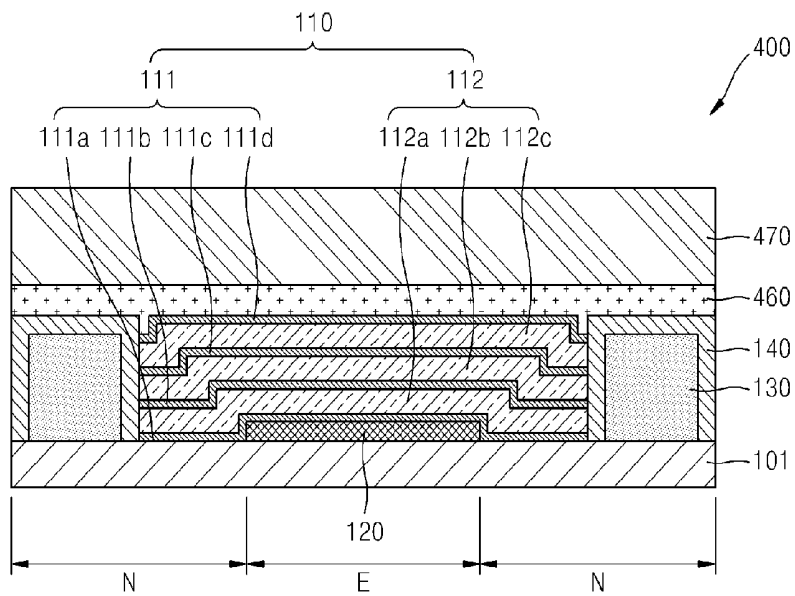

FIG. 6



**ORGANIC LIGHT EMITTING DIODE (OLED)  
DISPLAY****CROSS-REFERENCE TO RELATED PATENT  
APPLICATION**

[0001] This application claims the benefit of Korean Patent Application No. 10-2012-0129101, filed on Nov. 14, 2012, in the Korean Intellectual Property Office, the disclosure of which is incorporated herein in its entirety by reference.

**BACKGROUND**

[0002] 1. Field

[0003] The described technology generally relates to an organic light emitting diode (OLED) display.

[0004] 2. Description of the Related Technology

[0005] OLED displays generally have a faster response speed and an enhanced image quality over liquid crystal displays (LCDs), which are currently widely commercialized. Also, OLED displays are self-emissive and thus have a wide angle of view, and have high luminance, and thus are noticed as next-generation displays.

[0006] An OLED display generally includes a pixel electrode and an opposite electrode facing each other and an emissive layer including an organic material interposed between the pixel electrode and the opposite electrode.

**SUMMARY**

[0007] One inventive aspect is an organic light emitting diode (OLED) display in which penetration of water or a gas such as oxygen from the outside may be prevented.

[0008] Another aspect is an organic light emitting diode (OLED) display comprising: a substrate having a light emission area and a non-emission area outside the light emission area; an organic light emitting unit formed on the light emission area to surround the organic light emitting unit; a coating unit formed to coat an external surface of the blocking unit; and an encapsulation unit formed by alternately stacking at least one first thin film and at least one second thin film on an area surrounded by the blocking unit so as to encapsulate the organic light emitting unit.

[0009] The encapsulation unit may be formed by alternately stacking the at least one first thin film and the at least one second thin film in a direction away from the organic light emitting unit.

[0010] The at least one first thin film may be formed of an inorganic material.

[0011] The at least one first thin film may be a single layer formed of one of aluminum oxide (AlOx), silicon nitride (SiNx), silicon oxide (SiOx), and magnesium oxide (MgO).

[0012] The at least one first thin film may have a multi-layer nanolaminate structure in which a plurality of single layers formed of different materials are included.

[0013] The at least one second thin film may be formed of an organic material.

[0014] The blocking unit may have a height that is identical to or greater than a height of the encapsulation unit.

[0015] The blocking unit may be formed of an organic material.

[0016] The coating unit may be formed of an inorganic material. The blocking unit may comprise a first blocking member that is disposed on the non-emission area to surround the organic light emitting unit and a second blocking member

that is disposed on and further toward an outer portion of the non-emission area than the first blocking member to surround the first blocking member.

[0017] The first blocking member and the second blocking member may be separated from each other, and an intermediate member may be further disposed between the first blocking member and the second blocking member.

[0018] The coating unit may coat surfaces of the first blocking member, the second blocking member, and the intermediate member.

[0019] The first blocking member, the second blocking member, and the intermediate member may be formed of an organic material.

[0020] The blocking unit may comprise a first blocking member that is disposed on the non-emission area to surround the organic light emitting unit, a second blocking member that is disposed on and further toward an outer portion of the non-emission area than the first blocking member to surround the first blocking member, and a third blocking member that is disposed on and further toward the outer portion of the non-emission area than the second blocking member to surround the second blocking member.

[0021] The second blocking member may have a height that is greater than a height of the first blocking member and smaller than a height of the third blocking member.

[0022] The encapsulation unit may have a plurality of second thin films, and the height of the first blocking member is the same as or greater than a height of a first second thin film that is disposed at a lowermost end among the plurality of second thin films.

[0023] The encapsulation unit may have a plurality of second thin films, and the height of the second blocking member may be the same as or greater than a height of a thin film that is disposed at a second lowermost end among the plurality of second thin films.

[0024] The encapsulation unit may have more than three second thin films, and the height of the third blocking member is the same as or greater than a height of a third second thin film that is disposed at a third lowermost end among the plurality of second thin films.

[0025] The first blocking member, the second blocking member, and the third blocking member may be separated from one another.

[0026] The encapsulation unit may have a plurality of second thin films, and a first second thin film may be disposed at a lowermost end among the plurality of second thin films is disposed between the organic light emitting unit and the first blocking member.

[0027] The encapsulation unit may have a plurality of second thin films, and a thin film may be disposed at a second lowermost end among the plurality of second thin films is disposed between the first blocking member and the second blocking member.

[0028] The encapsulation unit may have more than three second thin films, and a third second thin film may be disposed at a third lowermost end among the plurality of second thin films is disposed between the second blocking member and the third blocking member.

[0029] The organic light emitting display apparatus may further comprise: a moisture absorbent covering upper portions of the encapsulation unit and the coating unit; and a film covering the moisture absorbent.

## BRIEF DESCRIPTION OF THE DRAWINGS

[0030] FIG. 1 is a schematic cross-sectional view of an organic light emitting diode (OLED) display apparatus according to an embodiment.

[0031] FIG. 2 is a schematic plan view of the OLED display of FIG. 1 according to an embodiment.

[0032] FIG. 3 is a cross-sectional view of the OLED display of FIG. 1 cut along a line II-II according to an embodiment.

[0033] FIG. 4 is a schematic cross-sectional view of an OLED display according to another embodiment.

[0034] FIG. 5 is a schematic cross-sectional view of an OLED display according to another embodiment.

[0035] FIG. 6 is a schematic cross-sectional view of an OLED display according to another embodiment.

## DETAILED DESCRIPTION

[0036] Generally, an OLED display is highly sensitive to water, oxygen, light or the like. When in contact with a liquid such as water, a gas such as oxygen, or when exposed to light, the display may easily deteriorate. Furthermore, if oxygen or water diffuses into an organic material layer, an electrochemical charge motion occurs on an interface between an electrode and the organic material layer to create an oxide. The oxide separates the organic material layer from the pixel electrode or the opposite electrode, causing a phenomenon such as dark spots. As a result, the lifespan of the OLED display decreases. The OLED display has low durability to heat, and thus when a temperature increases from about 30° to about 60°, the lifespan of the OLED display is known to decrease by about 20 times. Accordingly, an encapsulation method is typically used in order to prevent penetration of water, oxygen, light and the like from the outside into the OLED display.

[0037] Embodiments will now be described more fully with reference to the accompanying drawings. Expressions such as “at least one of,” when preceding a list of elements, modify the entire list of elements and do not modify the individual elements of the list.

[0038] FIG. 1 is a schematic cross-sectional view of an OLED display 100 according to an embodiment. FIG. 2 is a schematic plan view of the OLED display 100 of FIG. 1 according to an embodiment.

[0039] Referring to FIGS. 1 and 2, the OLED display 100 may include a substrate 101, an organic light emitting unit 120, an encapsulation unit 110, a blocking unit 130, and a coating unit 140.

[0040] The substrate 101 has a light emission area E and a non-emission area N. The light emission area E may be disposed in a central portion of the substrate 101, and the non-emission area N may be disposed in an outer portion of the substrate 101 to surround the light emission area E. The organic light emitting unit 120 may be formed on the light emission area E, and a portion of the encapsulation unit 110 and the blocking unit 130 may be formed on the non-emission area N.

[0041] The substrate 101 may be formed of a transparent glass material having silicon dioxide (SiO<sub>2</sub>) as a main component. However, the substrate 101 is not limited thereto and may also be formed of various materials such as a transparent plastic material or a metal. A buffer layer 51 (see FIG. 3) may be further formed on the substrate 101 depending on the embodiment.

[0042] The organic light emitting unit 120 may include a plurality of OLEDs and a thin film transistor TFT. The

OLEDs of the organic light emitting unit 120 each include a pixel electrode, an opposite electrode facing the pixel electrode, and an intermediate layer including an emissive layer and interposed between the pixel electrode and the opposite electrode. This will be described later in detail.

[0043] The blocking unit 130 may be formed on the non-emission area N of the substrate 101 to surround the organic light emitting unit 120. In one embodiment, the blocking unit 130 is separated by a distance from a side of the organic light emitting unit 120 to surround side portions of the organic light emitting unit 120. The blocking unit 130 may be formed of a photosensitive material such as polyimide (PI). The blocking unit 130 may also be formed during the same manufacturing operation as a pixel defining layer 60 (see FIG. 3) and of the same material as the pixel defining layer 60. In one embodiment, the blocking unit 130 is formed to have a height h that is greater than a thickness t of the organic light emitting unit 120. In space surrounded by the blocking unit 130, the encapsulation unit 110 may be formed to cover the organic light emitting unit 120. The encapsulation unit 110 will be described in detail later.

[0044] An external surface of the blocking unit 130 is coated with a coating unit 140. The blocking unit 130 may be formed of an organic material, and the coating unit 140 may be formed of an inorganic material such as an oxide metal, a nitride metal, an oxynitride metal, and a metal carbide. Also, the coating unit 140 may be formed substantially at the same time when forming a first thin film 111 of the encapsulation unit 110 which will be described later.

[0045] The encapsulation unit 110 encapsulates the organic light emitting unit 120 in the space formed by the blocking unit 130. The encapsulation unit 110 may be formed by alternately stacking first thin films 111 and second thin films 112. The first thin films 111 may include thin films 111a, 111b, 111c and 111d. The second thin films 112 may include thin films 112a, 112b, and 112c. That is, a thin film 111a is formed to directly encapsulate the organic light emitting unit 120, and a thin film 112a is formed on the thin film 111a. Also, a thin film 111b is formed on the thin film 112a, and a thin film 112b is formed on the thin film 111b. Furthermore, a thin film 111c is formed on the thin film 112b and a thin film 112c is formed on the thin film 111c. A thin film 111d may be formed on the thin film 112c. While the encapsulation unit 110 is formed of the first thin films 111a, 111b, 111c, and 111d and the second thin films 112a, 112b, and 112c, the embodiments are not limited thereto. The encapsulation unit 110 may be formed of at least one of the first thin films 111 and at least one of the second thin films 112. Also, when the encapsulation unit 110 is formed by alternately stacking a plurality of first thin films 111 and a plurality of second thin films 112, the uppermost portion of the encapsulation unit 110 may be formed by a first thin film 111. This is because the thin film 111a covers the organic light emitting unit 120 directly and then the second thin films 112 and the first thin films 111 are alternately stacked.

[0046] The encapsulation unit 110 is formed to cover an upper portion and a side portion of the organic light emitting unit 120 to substantially completely encapsulate the organic light emitting unit 120 as described above. Also, the encapsulation unit 110 is formed such that a side portion thereof is adhered to the coating unit 140. That is, the first thin films 111a, 111b, 111c, and 111d and the second thin films, 112a, 112b, and 112c substantially completely cover the organic

light emitting unit **120** and ends thereof and all contact the blocking unit **130** so as to substantially fill the space formed by the blocking unit **130**.

[0047] Each of the first thin films **111a**, **111b**, **111c**, and **111d** may be formed by using various typical thin film forming methods such as a sputtering method, a chemical vapor deposition (CVD) method, or a plasma enhanced chemical vapor deposition (PECVD).

[0048] When forming the first thin films **111a**, **111b**, **111c**, and **111d** by using the above-described methods, a shadow mask of substantially the same size may be used. That is, one sheet of shadow mask may be used to form the first thin films **111a**, **111b**, **111c**, and **111d**. Accordingly, the sizes, or surface areas, of the first thin films **111a**, **111b**, **111c**, and **111d** may be substantially the same. As one sheet of shadow mask is used to form the first thin films **111a**, **111b**, **111c**, and **111d**, the manufacturing costs may be reduced. In addition, as the first thin films **111a**, **111b**, **111c**, and **111d** are stacked by using one sheet of shadow mask, alignment tolerance of each of the first thin films **111a**, **111b**, **111c**, and **111d** may be reduced.

[0049] The first thin films **111** may be formed of an inorganic material. For example, the thin films **111a**, **111b**, **111c**, and **111d** may each be formed of a single layer formed of one of Aluminum oxide (AlOx), Silicon nitride (SiNx), Silicon oxide (SiOx), and Magnesium oxide (MgO). Also, the first films **111a**, **111b**, **111c**, and **111d** may each have a multi-layer nanolaminate structure in which single layers are formed of different layers. The nanolaminate structure refers to a structure in which thin films having different thicknesses measured in nanometers are alternately deposited. For example, if the first thin film **111a** has a nanolaminate structure, the thin film **111a** may have a structure in which an AlOx layer and a SiNx layer are alternately deposited.

[0050] The first thin films **111** formed of an inorganic material may function to block water or a gas such as oxygen. As described above, the penetration of water or a gas such as oxygen from the outside may be prevented by substantially completely encapsulating the organic light emitting unit **120**, thereby protecting the organic light emitting unit **120**.

[0051] The second thin films **112a**, **112b**, and **112c** may be formed by using typical thin film forming methods similar to those used in forming the first thin films **111a**, **111b**, **111c**, and **111d**. For example, methods such as a sputtering method, a CVD method, or a plasma CVD method may be used.

[0052] The second thin films **112a**, **112b**, and **112c** may be formed using the above-described methods by using one sheet of shadow mask. Accordingly, the second thin films **112a**, **112b**, and **112c** may be substantially the same sizes. As described above, as the second thin films **112a**, **112b**, and **112c** are formed by using one sheet of shadow mask, the manufacturing costs of the OLED display **100** may be reduced.

[0053] The second thin films **112** may be formed of an organic material. For example, the second thin films **112** may be formed of an acrylic resin. The second thin films **112a**, **112b**, and **112c** function to planarize surfaces of the first thin films **111a**, **111b**, and **111c** disposed therebelow.

[0054] In one embodiment, the second thin films **112** formed of an organic material do not directly contact the substrate **101**. Instead, the second thin films **112** may contact the first thin films **111** formed of an inorganic material and the coating unit **140**, thereby effectively preventing penetration of water or a gas such as oxygen. In one embodiment, when

forming the second thin films **112**, which are formed of an organic material, a surface condition thereof may be important. If an inorganic material layer is formed to cover the organic light emitting unit **120**, and if an organic material layer is formed to cover the inorganic material layer, a portion of the organic material layer is formed on the substrate **101**, and a portion of the organic material layer is formed on the inorganic material layer. As the portion of the organic material layer formed on the substrate **101** and the portion of the organic material layer formed on the inorganic material layer become to have different surface conditions, fine gaps may be formed between the organic material layer and the substrate **101** or between the organic material layer and the inorganic material layer, and thus damage to the organic light emitting unit **120** due to penetration of water or gas from the outside may be caused. However, as the second thin films **112** are formed to be surrounded by the first thin films **111** and by the coating unit **140** according to the current embodiment, all of the second thin films **112** may have substantially uniform characteristics.

[0055] Also, the OLED display **100** according to the current embodiment may prevent penetration of water or a gas such as oxygen through not only an upper portion of the organic light emitting unit **120** but also through lateral sides of the organic light emitting unit **120**. That is, as the first thin films **111** and the second thin films **112** are alternately stacked on the organic light emitting unit **120**, penetration of water or a gas such as oxygen through the upper portion of the organic light emitting unit **120** may be prevented. In addition, as the blocking unit **130** is formed at a side portion of the organic light emitting unit **120** so as to surround the encapsulation unit **110**, and as the coating unit **140** formed of an inorganic material is coated on an external surface of the blocking unit **130**, water or a gas such as oxygen penetrating through lateral sides of the OLED display **100** may be prevented.

[0056] FIG. 3 is a cross-sectional view of the OLED display **100** of FIG. 1 cut along a line according to an embodiment.

[0057] Referring to FIG. 3, the organic light emitting unit having an active matrix type is formed on the substrate **101**, and the organic light emitting unit may include an OLED and a thin film transistor (TFT). However, the embodiments are not limited thereto, and the organic light emitting unit **120** may also be a passive matrix type.

[0058] The substrate **101** may be formed of a transparent material such as a glass material, a plastic material, or a metal as described above. An insulating layer **51** such as a buffer layer may be formed overall on the substrate **101**.

[0059] A TFT and an OLED as illustrated in FIG. 3 are formed on the insulating layer **51**.

[0060] A semiconductor active layer **52** that is arranged in a predetermined pattern is formed on an upper surface of the insulating layer **51**. The semiconductor active layer **52** is covered by a gate insulating layer **53**. The active layer **52** may be formed of a p-type or n-type semiconductor.

[0061] A gate electrode **54** of a TFT is formed on an upper surface of the gate insulating layer **53** in a position corresponding to the active layer **52**. Also, an interlayer insulating layer **55** is formed to cover the gate electrode **54**. After the interlayer insulating layer **55** is formed, the gate insulating layer **53** and the interlayer insulating layer **55** may be etched using an etching operation such as a dry etching method to thereby form contact holes and expose a portion of the active layer **52**.

[0062] Next, source/drain electrodes **56** and **57** are formed on the interlayer insulating layer **55** so as to contact the active layer **52** that is exposed via a contact hole. A protection layer **58** is formed to cover the source/drain electrodes **56** and **57**, and a portion of the drain electrode **57** is exposed by using an etching operation. An additional insulating layer **59** may be further formed on the protection layer **58** in order to planarize the protection layer **58**.

[0063] Then, a first electrode **61** is formed on the protection layer **58**. The first electrode **61** is electrically connected to the drain electrode **57** of the TFT.

[0064] Also, a pixel defining layer **60** is formed to cover the first electrode **61**. A predetermined opening portion is formed in the pixel defining layer **60**, and an organic layer **62** including an emissive layer is formed in an area limited to this opening portion. A second electrode **63** is formed on the organic layer **62**.

[0065] The pixel defining layer **60** partitions each pixel and is formed of an organic material to planarize a surface of the substrate **101** on which the first electrode **61** is formed, particularly, a surface of the insulating layer **59**.

[0066] The first electrode **61** and the second electrode **63** are insulated from each other, and voltages of different polarities are applied to the organic layer **62** including the emissive layer so as to allow light emission.

[0067] The organic layer **62** including the emissive layer may be formed of a low molecular organic material or a polymer organic material. When formed of a low molecular weight non-polymeric organic material, the organic layer **62** may include a hole injection layer (HIL), a hole transport layer (HTL), an emission layer (EML), an electron transport layer (ETL), an electron injection layer (EIL) or the like, which are stacked in a single structure or a complex structure. Examples of organic materials that may be used are various as copper phthalocyanine (CuPc), N,N'-Di(naphthalene-1-yl)-N,N'-diphenyl-benzidine (NPB), tris-8-hydroxyquinoline aluminum (Alq3).

[0068] After forming the organic layer **62**, the second electrode **63** may be formed by using the same deposition method.

[0069] Meanwhile, the first electrode **61** may function as an anode electrode, and the second electrode **63** may function as a cathode electrode, and polarities of the first electrode **61** and the second electrode **63** may be exchanged. Also, the first electrode **61** may be patterned so as to correspond to each area of each pixel, and the second electrode **63** may be formed to cover all pixels.

[0070] The first electrode **61** may be formed of a transparent electrode or a reflective electrode; when the first electrode **61** is used as a transparent electrode, it may be formed of ITO, IZO, ZnO, or  $\text{In}_2\text{O}_3$ , and when the first electrode **61** is used as a reflective electrode, it may be formed by forming a reflective layer using Ag, Mg, Al, Pt, Pd, Au, Ni, Nd, Ir, Cr, or a compound of these and then forming a transparent electrode thereon of ITO, IZO, ZnO, or  $\text{In}_2\text{O}_3$ . The first electrode **61** is formed, for example, by using a sputtering method, and then patterned using a photo-lithography method.

[0071] Meanwhile, the second electrode **63** may also be formed of a transparent electrode or a reflective electrode. When the second electrode **63** is formed of a transparent electrode, it is used as a cathode electrode, and thus, first, a metal having a small work function, such as Li, Ca, LiF/Ca, LiF/Al, Al, Ag, Mg, and a compound thereof is deposited to be in a direction of the organic layer **62** including an emissive layer, and then an auxiliary electrode layer or a bus electrode

line may be formed of ITO, IZO, ZnO, or  $\text{In}_2\text{O}_3$  thereon. Also, when the second electrode **63** is used as a reflective electrode, Li, Ca, LiF/Ca, LiF/Al, Al, Ag, Mg, and a compound thereof are deposited on the entire surface of the organic layer **62**. Here, deposition may be performed in the same manner as in the case of the organic layer **62** including the above-described emissive layer.

[0072] FIG. 4 is a schematic cross-sectional view of an OLED display **200** according to another embodiment.

[0073] Referring to FIG. 4, the OLED display **200** is different from the OLED display **100** of FIG. 1 in terms of a blocking unit **230** and an intermediate member **250**. That is, a substrate **101**, an organic light emitting unit **120**, a plurality of first thin films **111**, and a plurality of second thin films **112** of the OLED display **200** are substantially the same as or similar to those of the OLED display **100** described above. Thus, description of common elements will be omitted but the blocking unit **230** and the intermediate member **250** will be described.

[0074] The blocking unit **230** may be formed of a first blocking member **231** and a second blocking member **232**. The first blocking member **231** may be disposed on a non-emission area N of the substrate **101** to surround the organic light emitting unit **120**. Also, the second blocking member **232** is disposed on the non-emission area N of the substrate **101** but may be formed further toward an outer portion than the first blocking member **231** to surround the first blocking member **231**.

[0075] The first blocking member **231** and the second blocking member **232** may be separated from each other, and the intermediate member **250** may be disposed between the first blocking member **231** and the second blocking member **232**. The intermediate member **250** may be formed of an acrylic member. The first blocking member **231**, the second blocking member **232**, and the intermediate member **250** may all be formed to have a height greater than a thickness of the organic light emitting unit **120**.

[0076] The first blocking member **231**, the second blocking member **232**, and the intermediate member **250** may be separated from one another, and a coating unit **240** may be formed on external surfaces of the first blocking member **231**, the second blocking member **232**, and the intermediate member **250**.

[0077] The first blocking member **231**, the second blocking member **232**, and the intermediate member **250** may be formed of an organic material, and the coating unit **240** may be formed of an inorganic material. In this case, the coating unit **240**, the second blocking member **232**, the coating unit **240**, the intermediate member **250**, the coating unit **240**, the first blocking member **231**, and the coating unit **240** may be sequentially formed in a direction from a lateral side of the OLED display **100** toward the organic light emitting unit **120**. Accordingly, a stack structure in which inorganic and organic materials are stacked is also provided at the lateral side of the OLED display **200** as in the upper portion of the organic light emitting unit **120**. Accordingly, water or a gas such as oxygen penetrating through the lateral side of the OLED display **200** may be effectively prevented.

[0078] FIG. 5 is a schematic cross-sectional view of an OLED display **300** according to another embodiment.

[0079] Referring to FIG. 5, the OLED display **300** is different from the OLED display **100** of FIG. 1 in terms of a blocking unit **330** and an encapsulation unit **310**. That is, a substrate **101** and an organic light emitting unit **120** of the

OLED display **300** of FIG. **5** are substantially the same or similar to those of the OLED display **100** described above. Thus, description of common elements will be omitted but the blocking unit **330** and the encapsulation unit **310** will be described.

[0080] The blocking unit **330** may be formed of a first blocking member **331**, a second blocking member **332**, and a third blocking member **333**. The first blocking member **331** is disposed on a non-emission area **N** of the substrate **101** to surround the organic light emitting unit **120**. The second blocking member **332** is also disposed on the non-emission area **N** of the substrate **101**, but further toward an outer portion than the first blocking member **331** to surround the first blocking member **331**. The third blocking member **333** is also disposed on the non-emission area **N** of the substrate **101**, but more toward an outer portion than the second blocking member **332** to surround the second blocking member **332**.

[0081] Coating units **241**, **242**, and **243** may be formed on external surfaces of the first blocking member **331**, the second blocking member **332**, and the third blocking member **333**, respectively.

[0082] The first blocking member **331**, the second blocking member **332**, and the third blocking member **333** may have different heights. For example, as illustrated in FIG. **5**, the second blocking member **332** may have a height **h2** that is higher than a height **h1** of the first blocking member **331** and lower than a height **h3** of the third blocking member **333**.

[0083] The height **h1** of the first blocking member **331** may be the same as or greater than a height **t1** of a first second thin film **312a** which is disposed at the lowermost end on a surface of the substrate **101** from among a plurality of second thin films **312**, and the height **h2** of the second blocking member **332** may be the same as or greater than a height **t2** of a thin film **312b** stacked on a first second thin film **312a**, and the height **h3** of the third blocking member **333** may be the same as or greater than a height **t3** of a third second thin film **312c** stacked on a thin film **312b**.

[0084] The first blocking member **331**, the second blocking member **332**, and the third blocking member **333** may be separated from one another, and the plurality of second thin films **312** may be disposed between the first blocking member **331**, the second blocking member **332**, and the third blocking member **333**.

[0085] That is, the first second thin film **312a** disposed at the lowermost end among the plurality of second thin films **312** may cover a thin film **311a** and fill space between the organic light emitting unit **120** and the first blocking member **331**.

[0086] Also, the thin film **312b** which is disposed at a second lowermost end among the plurality of second thin films **312** may cover a second first thin film **311b** and fill space between the first blocking member **331** and the second blocking member **332**.

[0087] Also, the third second thin film **312c** which is disposed at a third lowermost end among the plurality of second thin films **312** may cover a third first thin film **311c** and fill space between the second blocking member **332** and the third blocking member **333**.

[0088] The first blocking member **331**, the second blocking member **332**, and the third blocking member **333** may be formed of an organic material, and the coating units **241**, **242**, and **243** may be formed of an inorganic material. In this case, the coating unit **243**, the third blocking member **333**, the coating unit **243**, the second thin film **312c**, the coating unit

**242**, the second blocking member **332**, the coating unit **242**, the second thin film **312b**, the coating unit **241**, the second blocking member **331**, the coating unit **241**, the second thin film **312a**, and the third thin film **311a** are sequentially formed in a direction from a lateral side of the OLED display **300** toward the organic light emitting unit **120**. Accordingly, a stack structure in which inorganic and organic materials are stacked is also provided at a lateral side of the OLED display **300** as in the upper portion of the organic light emitting unit **120**. Accordingly, water or a gas such as oxygen penetrating into a lateral side of the OLED display **300** may be effectively prevented.

[0089] FIG. **6** is a schematic cross-sectional view of an OLED display **400** according to another embodiment.

[0090] Referring to FIG. **6**, the OLED display **400** is different from the OLED display **100** of FIG. **1** in that a moisture absorbent **460** and a film **470** are further included therein.

[0091] The film **470** is disposed on the organic light emitting unit **120**, and may be a polarization film. The moisture absorbent **460** is disposed between the encapsulation unit **110** and the film **470**, and may cover both the encapsulation unit **110** and the coating unit **140**. The moisture absorbent **460** may absorb water or a gas such as oxygen that may penetrate through an upper portion of the OLED display **400**.

[0092] According to at least one of the disclosed embodiments, penetration of water or a gas such as oxygen from the outside, particularly, through lateral sides of an OLED display into the OLED display may be prevented.

[0093] While the above embodiments have been described with reference to the accompanying drawings, it will be understood by those of ordinary skill in the art that various changes in form and details may be made therein without departing from the spirit and scope of the following claims.

What is claimed is:

1. An organic light emitting diode (OLED) display comprising:

a substrate comprising a light emission area and a non-emission area surrounding the light emission area;  
an organic light emitting unit formed on the light emission area;  
a blocking unit disposed on the non-emission area to surround the organic light emitting unit;  
a coating unit covering an external surface of the blocking unit; and

an encapsulation unit encapsulating the organic light emitting unit, wherein encapsulation unit comprises at least one first thin film and at least one second thin film alternatively stacked on each other on an area surrounded by the blocking unit.

2. The OLED display of claim 1, wherein the at least one first thin film and the at least one second thin film are formed over the organic light emitting unit.

3. The OLED display of claim 1, wherein the at least one first thin film is formed of an inorganic material.

4. The OLED display of claim 1, wherein the at least one first thin film is a single layer formed of one of aluminum oxide (AlOx), silicon nitride (SiNx), silicon oxide (SiOx), and magnesium oxide (MgO).

5. The OLED display of claim 4, wherein the at least one first thin film has a multi-layer nanolaminate structure in which a plurality of single layers formed of different materials are included.

6. The OLED display of claim 1, wherein the at least one second thin film is formed of an organic material.

7. The OLED display of claim 1, wherein the blocking unit has a height that is substantially identical to or greater than the height of the encapsulation unit.

8. The OLED display of claim 1, wherein the blocking unit is formed of an organic material.

9. The OLED display of claim 1, wherein the coating unit is formed of an inorganic material.

10. The OLED display of claim 1, wherein the blocking unit comprises a first blocking member disposed on the non-emission area to surround the organic light emitting unit and a second blocking member disposed on and further toward an outer portion of the non-emission area than the first blocking member.

11. The OLED display of claim 10, wherein the first and second blocking members are separated from each other, and wherein an intermediate member is further disposed between the first and second blocking members.

12. The OLED display of claim 11, wherein the coating unit covers surfaces of the first blocking member, the second blocking member, and the intermediate member.

13. The OLED display of claim 11, wherein the first blocking member, the second blocking member, and the intermediate member are formed of an organic material.

14. The OLED display of claim 1, wherein the blocking unit comprises i) a first blocking member disposed on the non-emission area to surround the organic light emitting unit, ii) a second blocking member disposed on and further toward an outer portion of the non-emission area than the first blocking member, and iii) a third blocking member disposed on and further toward the outer portion of the non-emission area than the second blocking member.

15. The OLED display of claim 14, wherein the second blocking member has a height that is greater than the height of the first blocking member and less than the height of the third blocking member.

16. The OLED display of claim 15, wherein the encapsulation unit has a plurality of second thin films, and wherein the height of the first blocking member is substantially the same

as or greater than the height of a thin film disposed at the lowermost end among second thin films.

17. The OLED display of claim 15, wherein the encapsulation unit has a plurality of second thin films, and wherein the height of the second blocking member is substantially the same as or greater than the height of a thin film disposed at the second lowermost end among the second thin films.

18. The OLED display of claim 15, wherein the encapsulation unit has more than three second thin films, and wherein the height of the third blocking member is substantially the same as or greater than the height of a thin film disposed at the third lowermost end among the second thin films.

19. The OLED display of claim 14, wherein the first blocking member, the second blocking member, and the third blocking member are separated from one another.

20. The OLED display of claim 19, wherein the encapsulation unit comprises a plurality of second thin films, and wherein a thin film disposed at the lowermost end among the second thin films is disposed between the organic light emitting unit and the first blocking member.

21. The OLED display of claim 19, wherein the encapsulation unit comprises a plurality of second thin films, and wherein a thin film disposed at the second lowermost end among the plurality of second thin films is disposed between the first blocking member and the second blocking member.

22. The OLED display of claim 19, wherein the encapsulation unit comprises more than three second thin films, and wherein a thin film disposed at the third lowermost end among the second thin films is disposed between the second blocking member and the third blocking member.

23. The OLED display of claim 1, further comprising:

a moisture absorbent covering upper portions of the encapsulation unit and the coating unit; and

a film covering the moisture absorbent.

\* \* \* \* \*

专利名称(译)	有机发光二极管 ( OLED ) 显示器		
公开(公告)号	<a href="#">US20140132148A1</a>	公开(公告)日	2014-05-15
申请号	US13/801973	申请日	2013-03-13
[标]申请(专利权)人(译)	三星显示有限公司		
申请(专利权)人(译)	三星DISPLAY CO. , LTD.		
当前申请(专利权)人(译)	三星DISPLAY CO. , LTD.		
[标]发明人	JANG CHEOL KIM SEUNG HUN SONG SEUNG YONG		
发明人	JANG, CHEOL KIM, SEUNG-HUN SONG, SEUNG-YONG		
IPC分类号	H05B33/04		
CPC分类号	H05B33/04 H01L51/5246 H01L51/5256		
优先权	1020120129101 2012-11-14 KR		
其他公开文献	US9252388		
外部链接	<a href="#">Espacenet</a> <a href="#">USPTO</a>		

摘要(译)

公开了一种有机发光二极管 ( OLED ) 显示器。在一个方面, 显示器包括具有发光区域和发光区域外部的非发光区域的基板, 形成在发光区域上的有机发光单元和设置在非发光区域上的阻挡单元围绕有机发光单元。OLED显示器还包括: 涂覆单元, 形成为涂覆阻挡单元的外表面; 以及封装单元, 通过在由阻挡单元围绕的区域上交替堆叠至少一个第一薄膜和至少一个第二薄膜而形成, 以便封装有机发光单元。

